

**METER INSTALLATION ELEVATION DETAIL**  
NTS

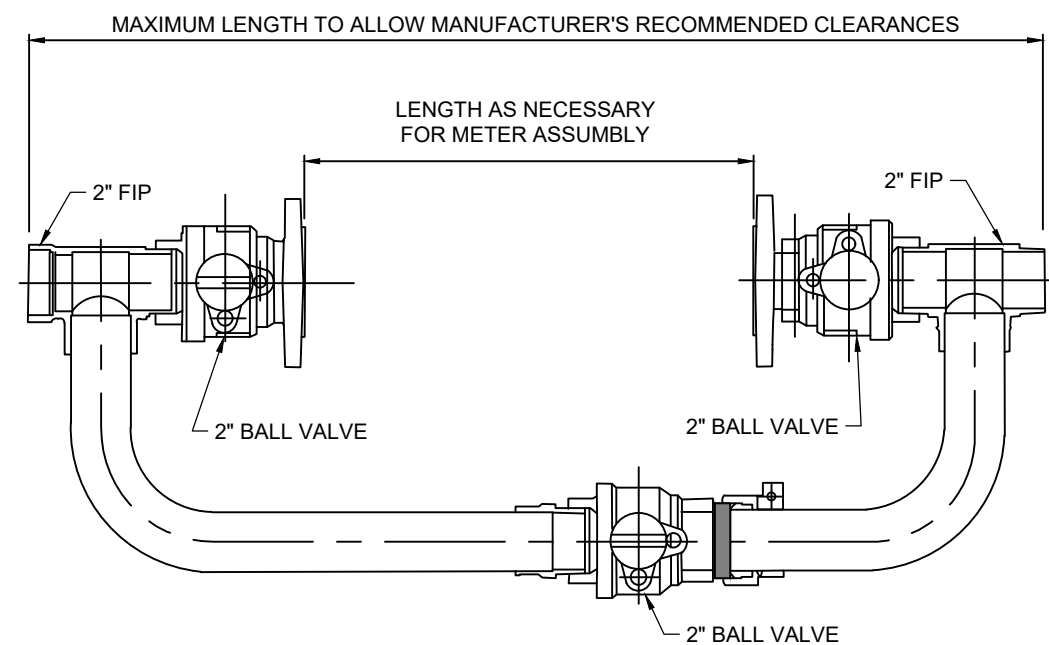

**BYPASS DETAIL**  
NTS

**NOTES:**

1. SERVICE LINE SHALL BE 2" DIAMETER FROM THE MAIN TO THE METER
2. USE ALL COMPRESSION GRIP JOINTS
3. INSTALLATION SHALL ALLOW ADEQUATE ROOM TO REMOVE AND/OR REPAIR METER
4. METER BOX SHALL BE APPROXIMATELY 24" X 36" X 18"
5. TYPE K COPPER SERVICE LINE MUST BE CONTINUOUS FROM METER TO MAIN.
6. SERVICE SHALL HAVE 18 IN. MINIMUM COVER AT METER AND 30 IN. MINIMUM COVER BETWEEN MAIN AND METER.

95% SUBMITTAL

FULTON COUNTY STANDARD DETAIL 804

2" WATER METER INSTALLATION

DATE	REVISIONS	DATE	REVISIONS
M/Y	XXX	M/Y	XXX

DGS/DRN/CHKD: XXX

APPROVED: XXX

DATE: XX-X-XX



FULTON COUNTY PUBLIC WORKS  
141 PRYOR ST. ATLANTA, GA. 30303  
404-612-7400 FAX: 404-224-0498

DRAWING NO.

804